

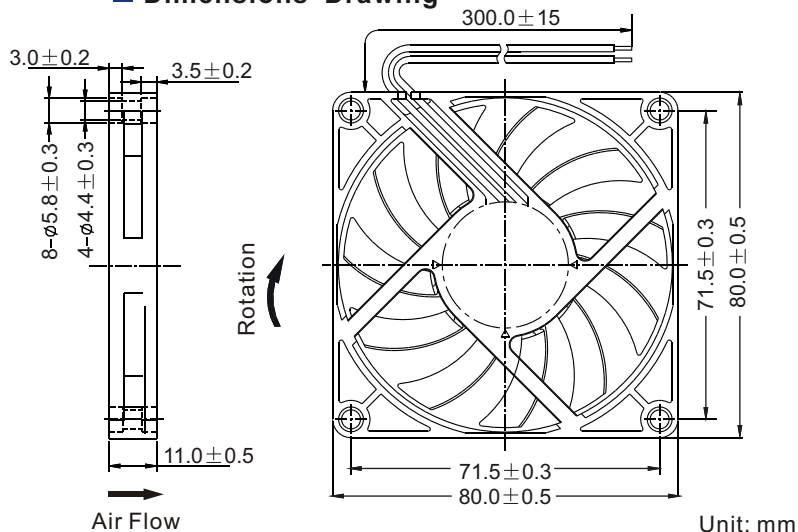

■ Dimensions Drawing



General Specification:

- Frame and Impeller : Thermal Plastic , UL 94V-0
- Lead Wires : UL Type  
(+) : Red (-) : Black
- Operation Temperature : -10°C~70°C、  
35%~85%RH
- Storage Temperature : -40°C~80°C、  
35%~85%RH



■ Performance Curves

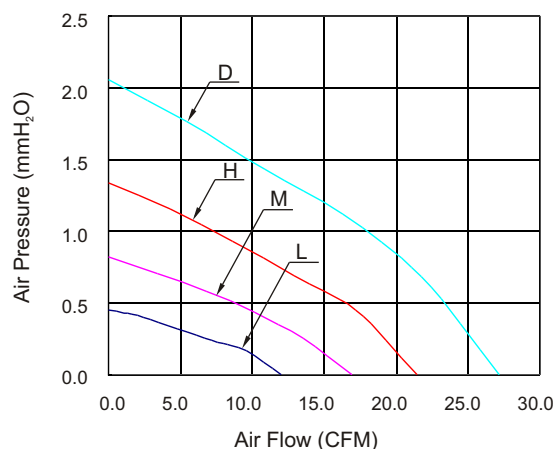

Listed Model	Bearing System	Rated Voltage	Operation Voltage	Rated Current	Rated Speed	Air Flow	Air Pressure	Noise Level	Available Features (Optional)				Weight g
		VDC	VDC	A	RPM	CFM	mmH <sub>2</sub> O	dBA	Tachometer Output	Rotation Detector	Thermal Control	Pulse Width Modulation	
RDD8010S5	Sleeve	5	3.5~5.75	0.35	3,000	27.1	2.0	33	•	•		•	38.5
RDH8010S5			3.5~5.75	0.23	2,500	21.4	1.3	28	•	•		•	
RDM8010S5			3.5~5.75	0.15	2,000	16.9	0.8	23	•	•		•	
RDL8010S5			3.5~5.75	0.10	1,500	12.0	0.4	20	•	•		•	
RDD8010B5	Ball		3.5~5.75	0.35	3,000	27.1	2.0	33	•	•		•	
RDH8010B5			3.5~5.75	0.23	2,500	21.4	1.3	28	•	•		•	
RDM8010B5			3.5~5.75	0.15	2,000	16.9	0.8	23	•	•		•	
RDL8010B5			3.5~5.75	0.10	1,500	12.0	0.4	20	•	•		•	
RDD8010S1	Sleeve	12	6.0~13.8	0.22	3,000	27.1	2.0	33	•	•		•	
RDH8010S1			6.0~13.8	0.16	2,500	21.4	1.3	28	•	•		•	
RDM8010S1			6.0~13.8	0.12	2,000	16.9	0.8	23	•	•		•	
RDL8010S1			6.0~13.8	0.08	1,500	12.0	0.4	20	•	•		•	
RDD8010B1	Ball		6.0~13.8	0.22	3,000	27.1	2.0	33	•	•		•	
RDH8010B1			6.0~13.8	0.16	2,500	21.4	1.3	28	•	•		•	
RDM8010B1			6.0~13.8	0.12	2,000	16.9	0.8	23	•	•		•	
RDL8010B1			6.0~13.8	0.08	1,500	12.0	0.4	20	•	•		•	

Notes: ©All readings are typical values at rated voltage.  
©Specifications are subjected to change without prior notice.