

■ Dimensions Drawing

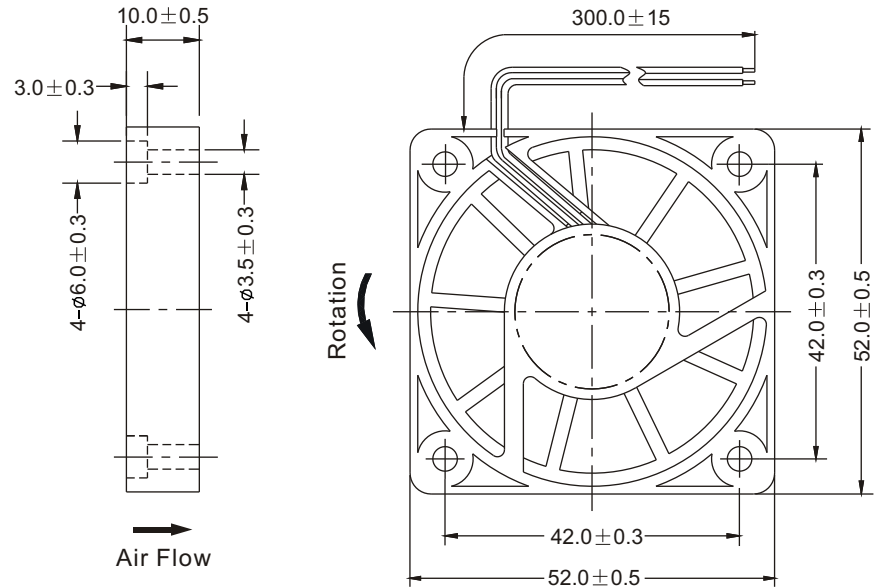

Unit: mm

General Specification:

- Frame and Impeller : Thermal Plastic , UL 94V-0
- Lead Wires : UL Type
(+) : Red (-) : Black
- Operation Temperature : -10°C~70°C、
38%~85%RH
- Storage Temperature : -40°C~80°C、
38%~85%RH



■ Performance Curves

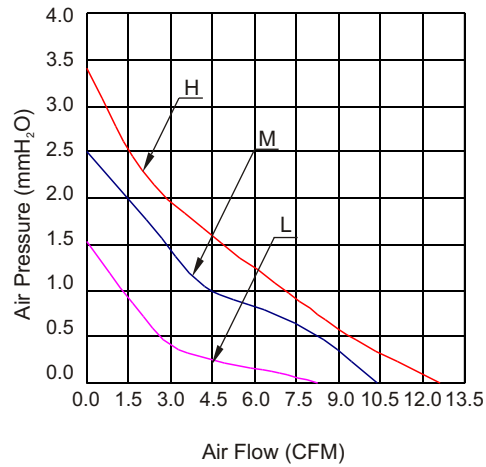

Listed Model	Bearing System	Rated Voltage	Operation Voltage	Rated Current	Rated Speed	Air Flow	Air Pressure	Noise Level	Available Features (Optional)				Weight
		VDC	VDC	A	RPM	CFM	mmH ₂ O	dBA	Tachometer Output	Rotation Detector	Thermal Control	Pulse Width Modulation	g
RDH5210S	Sleeve	12	6.0~13.8	0.14	6,000	12.6	3.4	38	•	•			22
RDM5210S			6.0~13.8	0.12	5,000	10.4	2.5	33	•	•			
RDL5210S			6.0~13.8	0.09	4,000	8.2	1.6	27	•	•			
RDH5210B	Ball		6.0~13.8	0.14	6,000	12.6	3.4	38	•	•			
RDM5210B			6.0~13.8	0.12	5,000	10.4	2.5	33	•	•			
RDL5210B			6.0~13.8	0.09	4,000	8.2	1.6	27	•	•			