

■ Dimensions Drawing

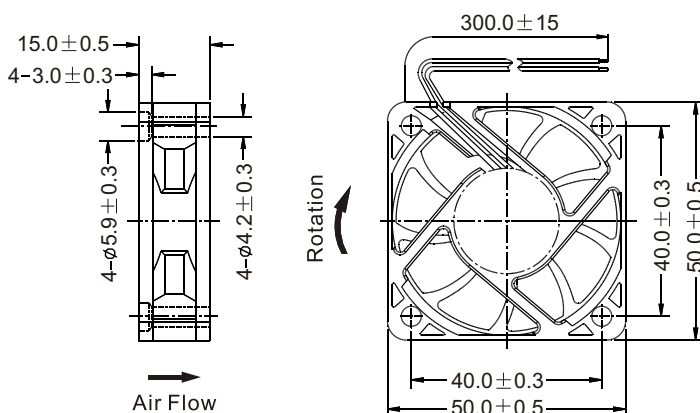

Unit: mm

■ Performance Curves

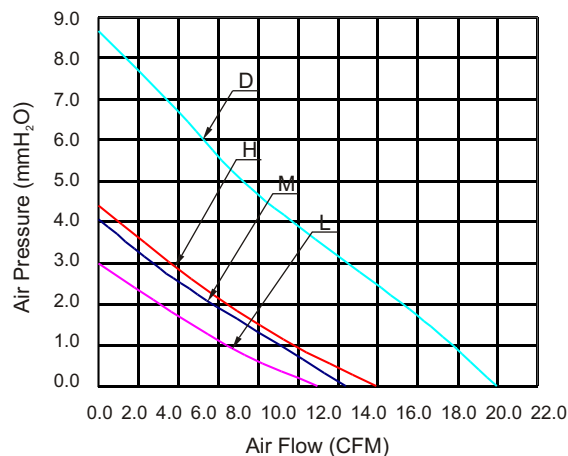

General Specification:

- Frame and Impeller : Thermal Plastic , UL 94V-0
- Lead Wires : UL Type  
(+) : Red (-) : Black
- Operation Temperature : -10°C~70°C、  
35%~85%RH
- Storage Temperature : -40°C~80°C、  
35%~85%RH



Listed Model	Bearing System	Rated Voltage	Operation Voltage	Rated Current	Rated Speed	Air Flow	Air Pressure	Noise Level	Available Features (Optional)				Weight
		VDC	VDC	A	RPM	CFM	mmH <sub>2</sub> O	dBA	Tachometer Output	Rotation Detector	Thermal Control	Pulse Width Modulation	g
RDH5015S5	Sleeve	5	3.5~5.75	0.33	5,500	13.9	4.4	32	•	•			30
RDM5015S5			3.5~5.75	0.25	5,000	12.4	4.1	30	•	•			
RDL5015S5			3.5~5.75	0.20	4,500	11.0	3.0	27	•	•			
RDH5015B5	Ball		3.5~5.75	0.33	5,500	13.9	4.4	32	•	•			
RDM5015B5			3.5~5.75	0.25	5,000	12.4	4.1	30	•	•			
RDL5015B5			3.5~5.75	0.20	4,500	11.0	3.0	27	•	•			
RDH5015S	Sleeve	12	6.0~13.8	0.16	5,500	13.9	4.4	32	•	•			
RDM5015S			6.0~13.8	0.14	5,000	12.4	4.1	30	•	•			
RDL5015S			6.0~13.8	0.12	4,500	11.0	3.0	27	•	•			
RDH5015B	Ball		6.0~13.8	0.16	5,500	13.9	4.4	32	•	•			
RDM5015B			6.0~13.8	0.14	5,000	12.4	4.1	30	•	•			
RDL5015B			6.0~13.8	0.12	4,500	11.0	3.0	27	•	•			
RDD5015S2	Sleeve	24	12.0~27.6	0.18	8,000	20.0	8.7	42	•	•			
RDH5015S2			12.0~27.6	0.10	5,500	13.9	4.4	32	•	•			
RDM5015S2			12.0~27.6	0.08	5,000	12.4	4.1	30	•	•			
RDL5015S2	12.0~27.6		0.06	4,500	11.0	3.0	27	•	•				
RDD5015B2	Ball		12.0~27.6	0.18	8,000	20.0	8.7	42	•	•			
RDH5015B2			12.0~27.6	0.10	5,500	13.9	4.4	32	•	•			
RDM5015B2		12.0~27.6	0.08	5,000	12.4	4.1	30	•	•				
RDL5015B2		12.0~27.6	0.06	4,500	11.0	3.0	27	•	•				

Notes: ©All readings are typical values at rated voltage.  
©Specifications are subjected to change without prior notice.