

50x50x12mm

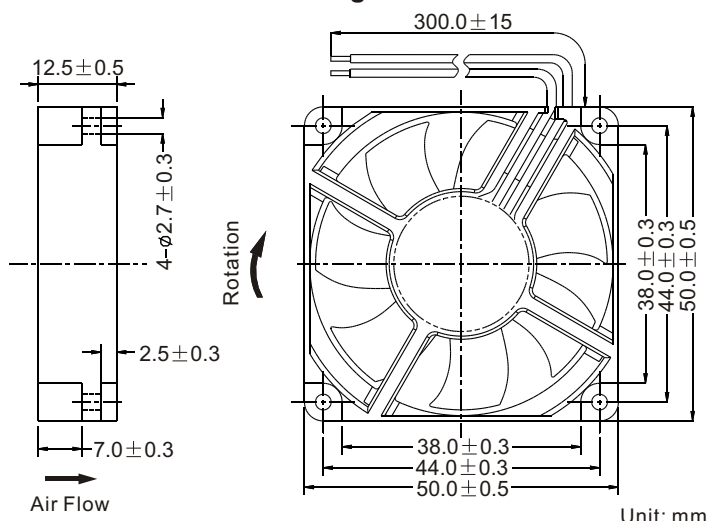

■ Dimensions Drawing



General Specification:

- Frame and Impeller : Thermal Plastic , UL 94V-0
- Lead Wires : UL Type
(+) : Red (-) : Black
- Operation Temperature : -10°C ~ 70°C ,
35% ~ 85%RH
- Storage Temperature : -40°C ~ 80°C ,
35% ~ 85%RH



■ Performance Curves

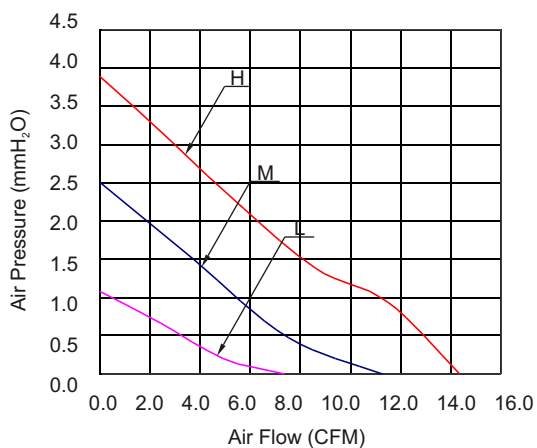

Listed Model	Bearing System	Rated Voltage	Operation Voltage	Rated Current	Rated Speed	Air Flow	Air Pressure	Noise Level	Available Features (Optional)				Weight
		VDC	VDC	A	RPM	CFM	mmH ₂ O	dBA	Tachometer Output	Rotation Detector	Thermal Control	Pulse Width Modulation	g
RDH5012S1	Sleeve	12	6.0~13.8	0.16	6,000	14.4	3.9	36	•	•			22
RDM5012S1			6.0~13.8	0.10	4,500	11.3	2.5	28	•	•			
RDL5012S1			8.0~13.8	0.06	3,000	7.4	1.1	20	•	•			
RDH5012B1	Ball		6.0~13.8	0.16	6,000	14.4	3.9	36	•	•			
RDM5012B1			6.0~13.8	0.10	4,500	11.3	2.5	28	•	•			
RDL5012B1			8.0~13.8	0.06	3,000	7.4	1.1	20	•	•			