

40x40x28mm

■ Dimensions Drawing

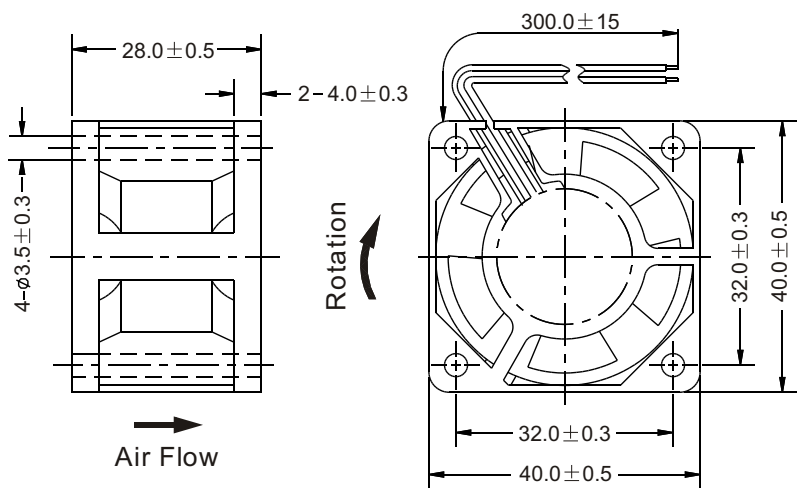

Unit: mm

General Specification:

- Frame and Impeller : Thermal Plastic , UL 94V-0
- Lead Wires : UL Type
(+) : Red (-) : Black
- Operation Temperature : -10°C~70°C、
35%~85%RH
- Storage Temperature : -40°C~80°C、
35%~85%RH



■ Performance Curves

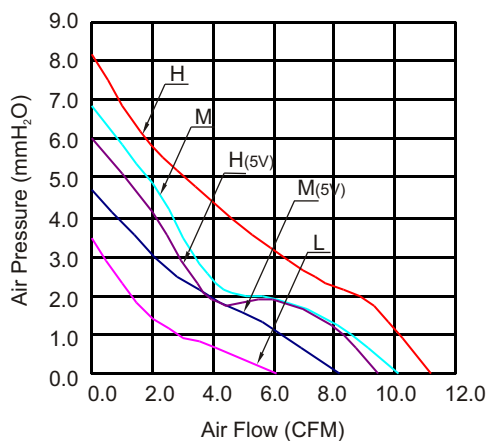

Listed Model	Bearing System	Rated Voltage	Operation Voltage	Rated Current	Rated Speed	Air Flow	Air Pressure	Noise Level	Available Features (Optional)				Weight g
		VDC	VDC	A	RPM	CFM	mmH ₂ O	dBA	Tachometer Output	Rotation Detector	Thermal Control	Pulse Width Modulation	
RDH4028S5	Sleeve	5	3.5~5.75	0.35	7,500	9.4	6.0	32	•	•			36
RDM4028S5			3.5~5.75	0.30	6,500	8.2	4.7	28	•	•			
RDL4028S5			3.5~5.75	0.22	5,000	6.1	3.5	23	•	•			
RDH4028B5	Ball		3.5~5.75	0.35	7,500	9.4	6.0	32	•	•			
RDM4028B5			3.5~5.75	0.30	6,500	8.2	4.7	28	•	•			
RDL4028B5			3.5~5.75	0.22	5,000	6.1	3.5	23	•	•			
RDH4028S	Sleeve	12	6.0~13.8	0.20	8,800	11.2	8.1	36	•	•			
RDM4028S			6.0~13.8	0.18	8,000	10.1	6.8	33	•	•			
RDL4028S			6.0~13.8	0.12	5,000	6.1	3.5	23	•	•			
RDH4028B	Ball		6.0~13.8	0.20	8,800	11.2	8.1	36	•	•			
RDM4028B			6.0~13.8	0.18	8,000	10.1	6.8	33	•	•			
RDL4028B			6.0~13.8	0.12	5,000	6.1	3.5	23	•	•			
RDH4028S2	Sleeve	24	12.0~27.6	0.16	8,800	11.2	8.1	36	•	•			
RDM4028S2			12.0~27.6	0.12	8,000	10.1	6.8	33	•	•			
RDL4028S2			12.0~27.6	0.09	5,000	6.1	3.5	23	•	•			
RDH4028B2	Ball		12.0~27.6	0.16	8,800	11.2	8.1	36	•	•			
RDM4028B2			12.0~27.6	0.12	8,000	10.1	6.8	33	•	•			
RDL4028B2			12.0~27.6	0.09	5,000	6.1	3.5	23	•	•			

Notes: ©All readings are typical values at rated voltage.
©Specifications are subjected to change without prior notice.