

■ Dimensions Drawing

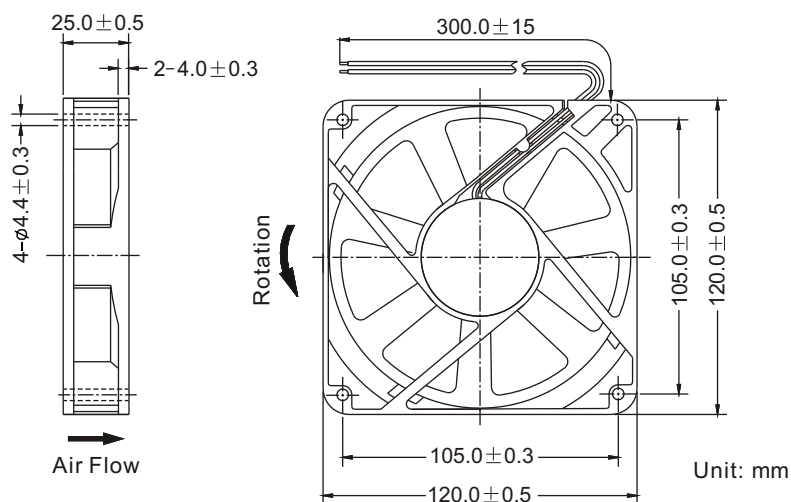

■ Performance Curves

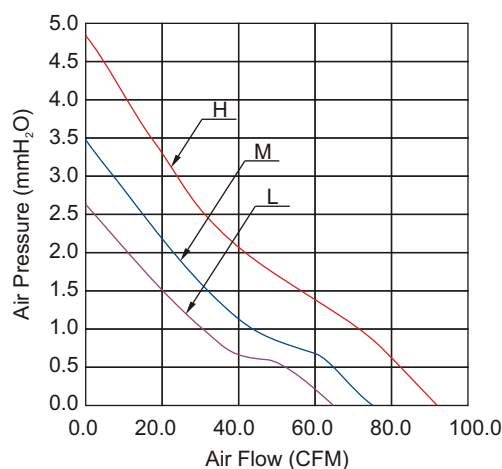

General Specification:

- Frame and Impeller : Thermal Plastic , UL 94V-0
- Lead Wires : UL Type  
(+) : Red (-) : Black
- Operation Temperature : -10°C~70°C、  
35%~85%RH
- Storage Temperature : -40°C~80°C、  
35%~85%RH



Listed Model	Bearing System	Rated Voltage	Operation Voltage	Rated Current	Rated Speed	Air Flow	Air Pressure	Noise Level	Available Features (Optional)				Weight
		VDC	VDC	A	RPM	CFM	mmH <sub>2</sub> O	dBA	Tachometer Output	Rotation Detector	Thermal Control	Pulse Width Modulation	
RDH1225S	Sleeve	12	6.0~13.8	0.40	2,400	91.6	4.8	44	•	•	•	•	164
RDM1225S			6.0~13.8	0.23	2,000	76.9	3.5	38	•	•	•	•	
RDL1225S			6.0~13.8	0.18	1,700	65.1	2.6	34	•	•	•	•	
RDH1225B	Ball		6.0~13.8	0.40	2,400	91.6	4.8	44	•	•	•	•	
RDM1225B			6.0~13.8	0.23	2,000	76.9	3.5	38	•	•	•	•	
RDL1225B			6.0~13.8	0.18	1,700	65.1	2.6	34	•	•	•	•	
RDH1225S2	Sleeve	24	12.0~27.6	0.35	2,400	91.6	4.8	44	•	•			
RDM1225S2			12.0~27.6	0.20	2,000	76.9	3.5	38	•	•			
RDL1225S2			12.0~27.6	0.13	1,700	65.1	2.6	34	•	•			
RDH1225B2	Ball		12.0~27.6	0.35	2,400	91.6	4.8	44	•	•			
RDM1225B2			12.0~27.6	0.20	2,000	76.9	3.5	38	•	•			
RDL1225B2			12.0~27.6	0.13	1,700	65.1	2.6	34	•	•			

Notes: ©All readings are typical values at rated voltage.  
©Specifications are subjected to change without prior notice.