

120x120x23mm

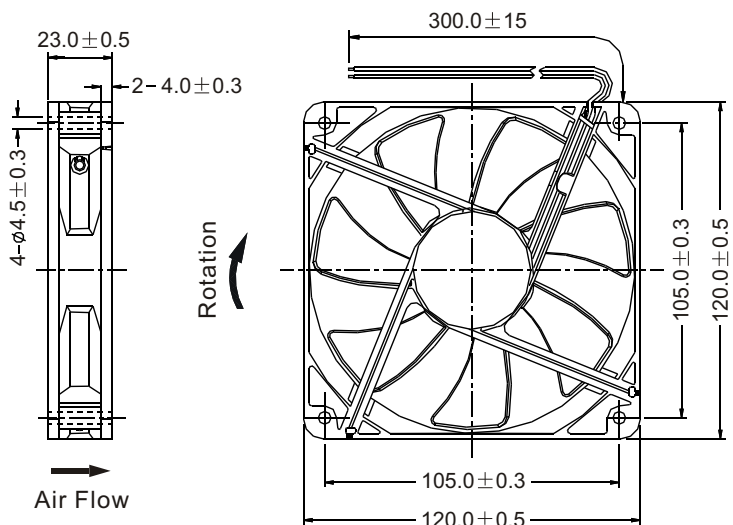

■ Dimensions Drawing



Unit: mm

General Specification:

- Frame and Impeller : Thermal Plastic , UL 94V-0
- Lead Wires : UL Type
(+) : Red (-) : Black
- Operation Temperature : -10°C~70°C、
35%~85%RH
- Storage Temperature : -40°C~80°C、
35%~85%RH

■ Performance Curves

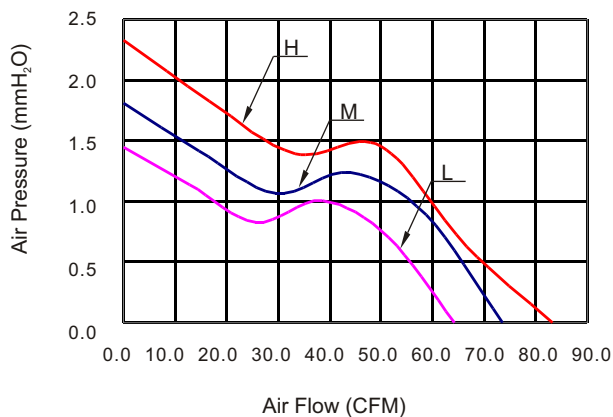

Listed Model	Bearing System	Rated Voltage	Operation Voltage	Rated Current	Rated Speed	Air Flow	Air Pressure	Noise Level	Available Features (Optional)				Weight
		VDC	VDC	A	RPM	CFM	mmH ₂ O	dBA	Tachometer Output	Rotation Detector	Thermal Control	Pulse Width Modulation	g
RDH1223S1	Sleeve	12	6.0~13.8	0.40	2,200	83.3	2.3	36	•	•		•	125
RDM1223S1			6.0~13.8	0.23	1,900	73.5	1.8	31	•	•		•	
RDL1223S1			6.0~13.8	0.18	1,700	64.3	1.5	29	•	•		•	