

30x30x06mm

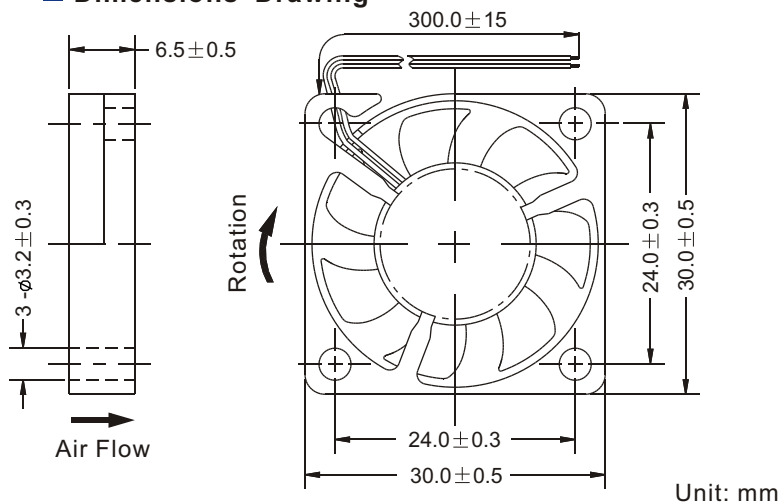

■ Dimensions Drawing



Unit: mm

General Specification:

- Frame and Impeller : Thermal Plastic , UL 94V-0
- Lead Wires : UL Type
(+) : Red (-) : Black
- Operation Temperature : -10°C~70°C、
35%~85%RH
- Storage Temperature : -40°C~80°C、
35%~85%RH



■ Performance Curves

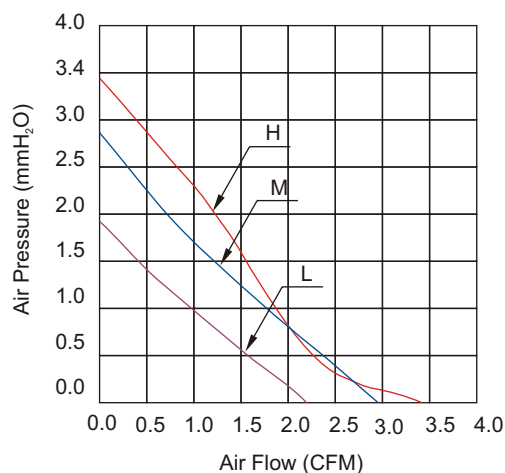

Listed Model	Bearing System	Rated Voltage	Operation Voltage	Rated Current	Rated Speed	Air Flow	Air Pressure	Noise Level	Available Features (Optional)				Weight g
		VDC	VDC	A	RPM	CFM	mmH ₂ O	dBA	Tachometer Output	Rotation Detector	Thermal Control	Pulse Width Modulation	
RDH3006S5	Sleeve	5	3.5~5.75	0.22	10,500	3.4	3.4	34	•				6
RDM3006S5			4.0~5.75	0.17	9,000	2.9	2.8	30	•				
RDL3006S5			4.5~5.75	0.13	7,500	2.2	1.9	26	•				
RDH3006B5	Ball		3.5~5.75	0.22	10,500	3.4	3.4	34	•				
RDM3006B5			4.0~5.75	0.17	9,000	2.9	2.8	30	•				
RDL3006B5			4.5~5.75	0.13	7,500	2.2	1.9	26	•				
RDH3006S1	Sleeve	12	6~13.8	0.12	10,500	3.4	3.4	34	•				6
RDM3006S1			8~13.8	0.10	9,000	2.9	2.8	30	•				
RDL3006S1			10~13.8	0.08	7,500	2.2	1.9	26	•				
RDH3006B1	Ball		6~13.8	0.12	10,500	3.4	3.4	34	•				
RDM3006B1			8~13.8	0.10	9,000	2.9	2.8	30	•				
RDL3006B1			10~13.8	0.08	7,500	2.2	1.9	26	•				

Notes: ©All readings are typical values at rated voltage.
©Specifications are subjected to change without prior notice.